

**Thanks to:**

Monitor National Marine Sanctuary (NOAA)  
 (Joe Hoyt, Lauren Heesemann, & David Alberg)  
 North Carolina Underwater Archaeology Branch  
 (Richard Lawrence, Mark Wilde-Ramsing, & Nathan Henry)  
 ECU Diving and Water Safety  
 (Mark Keusenkothen & Eric Diaddorrio)  
 UNC-CSI  
 (John McCord, Mike Muglia, & Nancy White)  
 Outer Banks Dive Center  
 (Bill McDermott)  
 Oriental History Museum  
 (Louis Ostendorff & Bob Verhaeghe)  
 ECU Program in Maritime Studies  
 (Bradley Rodgers)

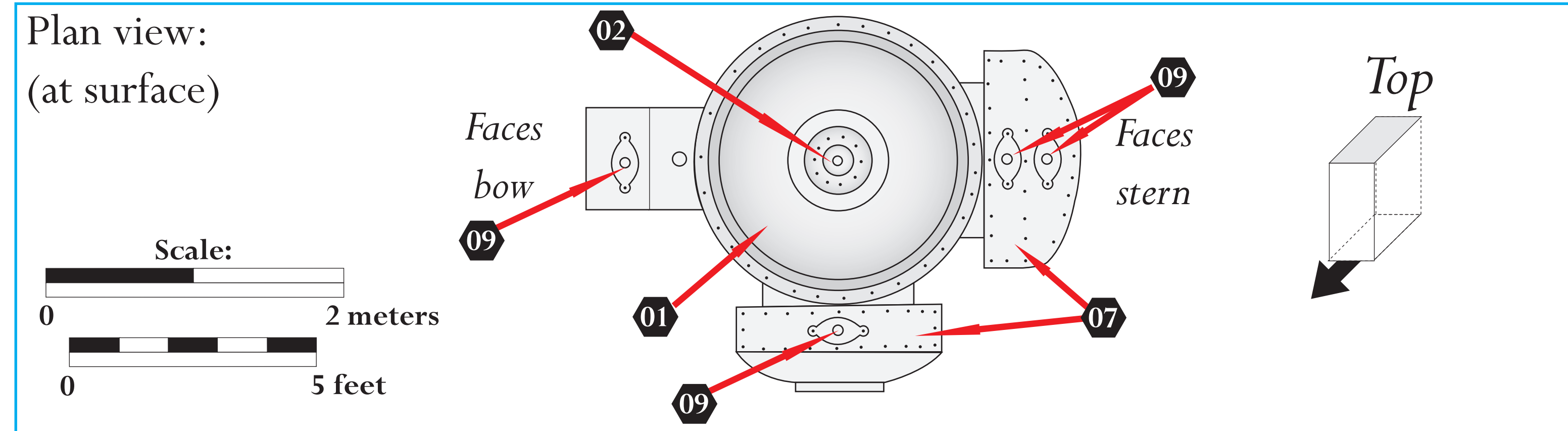

Divers descend adjacent to Oriental's engine  
 Photo: Dan Brown



**Recorded by:**  
 Nathan Richards, Calvin Mires, Stephen Dilk,  
 Daniel Bera, Saxon Bisbee, John Bright,  
 Dan Brown, Kathryn Cooper, Nat Howe,  
 Joshua Marano, Jeff O'Neill, William Schilling,  
 & David Sybert

**Digitization by:**  
 Nathan Richards

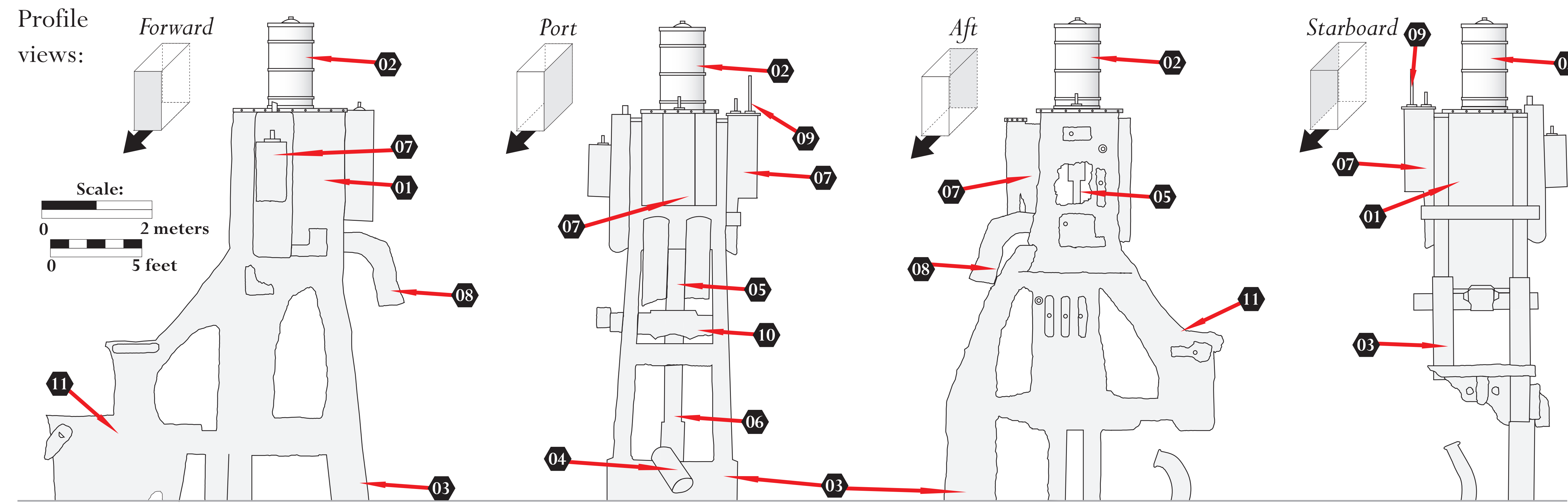

Daniel Bera records Oriental's engine  
 Photo: Dan Brown

- Key:
- 01 Low pressure cylinder
  - 02 High pressure cylinder
  - 03 Engine frame
  - 04 Crankshaft
  - 05 Piston rod
  - 06 Connecting rod
  - 07 Valve chest
  - 08 Exhaust to condenser
  - 09 Valve stem guide
  - 10 Crosshead
  - 11 Reversing gear

**Oriental (PEB0008)**

**Federal Troop Transport (1861 - 16 May 1862)**

Twin cylinder vertical tandem compound engine: 7-11 June 2010

**Pea Island Beach, Atlantic Ocean, NC**

(Lat. 35.7181°N Long. 75.4898°W)

